

HP No 739 498NOA Designjet Printhead

Clean, align or replace

Clean the printhead from the control panel

When your print quality seems poor, and you are next to the printer, this is a simple method to address the issue.

1. Make sure there is paper in the input tray or a roll loaded.
2. Go to the control panel and tap the **Menu icon** , then **Tools > Troubleshooting > Printhead Cleaning**.

Align the printhead

Precise printhead alignment is essential for good area fill, line quality, and sharp edges in graphical elements.

Your printer has an automatic printhead alignment process which runs whenever a printhead has been accessed or replaced. You may need to align the printhead after a paper jam or if you are experiencing print-quality problems.

 **IMPORTANT:** Load minimum A4 and letter size paper. Do not load them in landscape.

1. Load the paper you wish to use, see [Paper handling on page 22](#). You can use a roll or a cut sheet; plain white paper is recommended.

 **CAUTION:** Do not use transparent or semi-transparent paper to align the printhead.

2. Ensure that the window is closed, as a strong light source near the printer during printhead realignment can affect alignment.
3. From the control panel, tap the **Menu icon** , then **Tools > Troubleshooting > Printhead Alignment**.

 **NOTE:** Printhead alignment can also be started from the Embedded Web Server (**Print Quality > Tools > Printhead Alignment**).



4. If the loaded paper is satisfactory, the printer runs the realignment and prints a realignment pattern.
5. The process takes about five minutes. Wait until the control-panel display shows the process complete before using the printer.

If the printer cannot complete the printhead alignment successfully, you may be asked to clean the printhead and try again.

Replace the printhead

When the printhead is out of ink or has an issue that cannot be fixed, you must replace it. After replacement, the printer will automatically perform a printhead alignment on the loaded paper.

 **TIP:** If you would like to perform the printhead alignment on a different paper (perhaps from the tray), you could change the paper before starting this procedure. Plain white paper is recommended. A4 and letter paper should not be loaded in landscape orientation.

1. Make sure the printer is turned on.
2. Make sure the printer wheels are locked (the brake lever is pressed down) to prevent the printer from moving.
3. From the control panel, tap the **Menu** icon , then the **Supplies** icon , then **Printheads** > **Replace Printhead**. Follow the instructions on the control panel.
4. Open the main door.

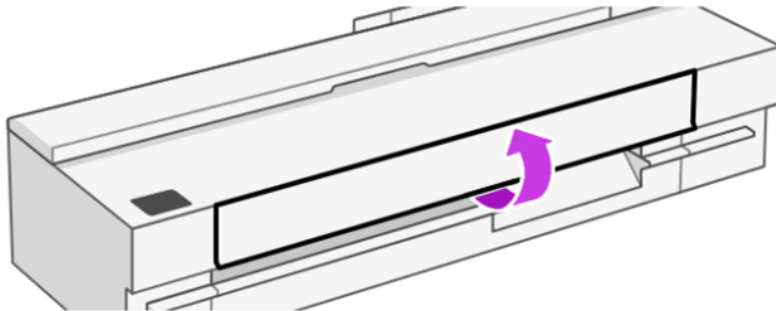

5. Open the printhead door on the right-hand side of the printer.

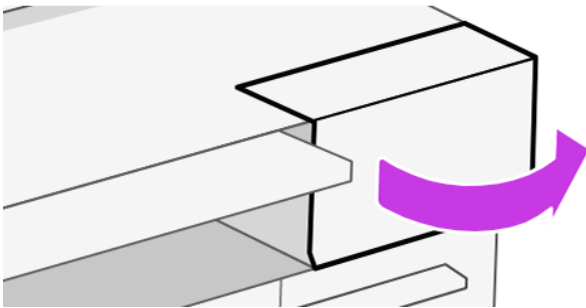

6. Locate the tubes connector-lever to release the ink tubes.

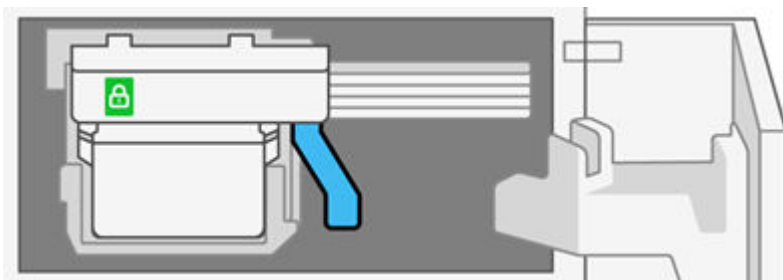

7. Raise the lever to release the tube connector and store the tubes connector on the tubes connector-holder in the printer door.

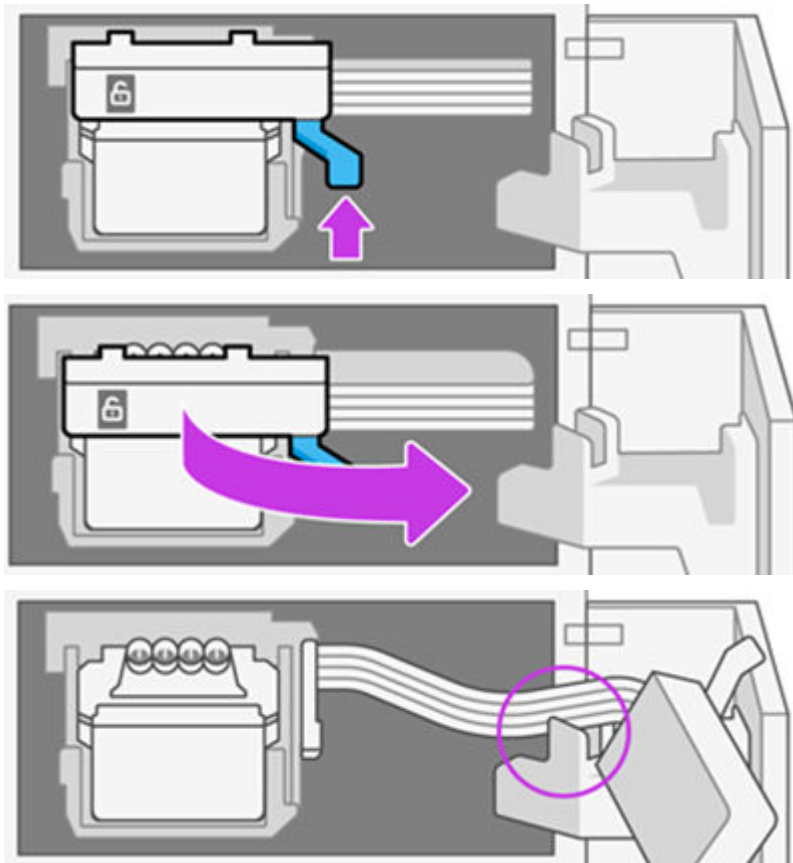

8. Locate the printhead lever.

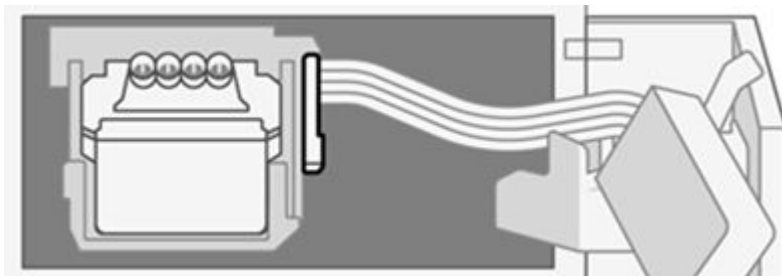

9. Raise the lever to release the printhead.

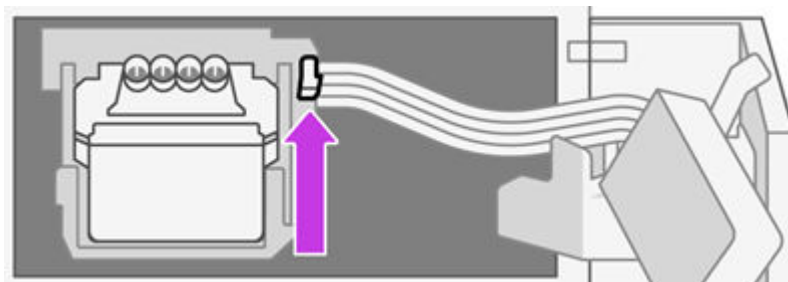

10. Remove the printhead, handling it with care to avoid getting ink on the connections.

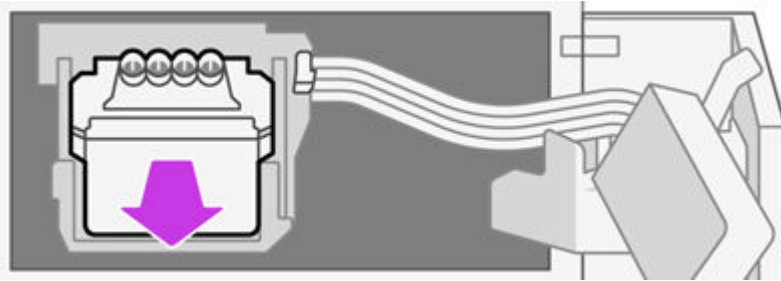

11. Insert the new printhead.

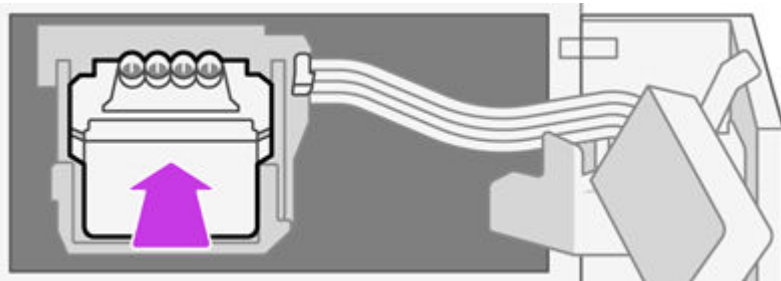

12. Lower the printhead lever (white).

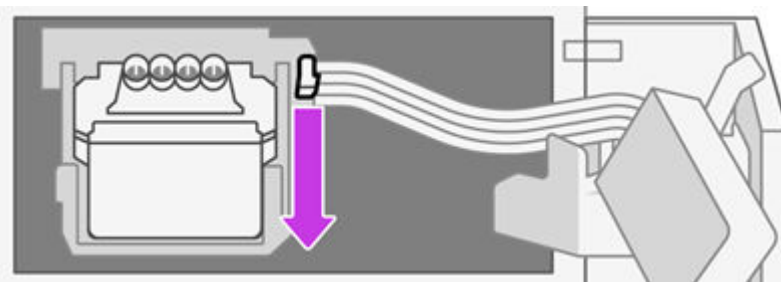

13. Insert the tubes connector into the printhead.

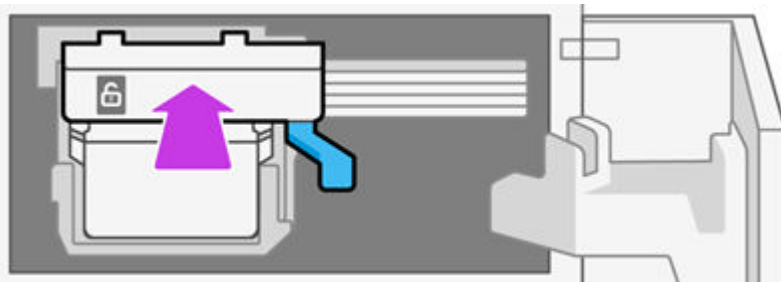

14. Make sure that the tubes connector locks shut.

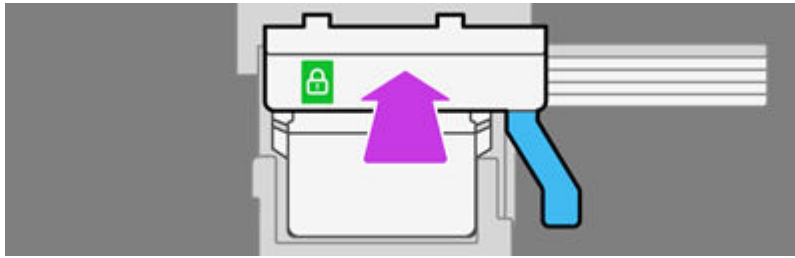

15. Close the printhead door.

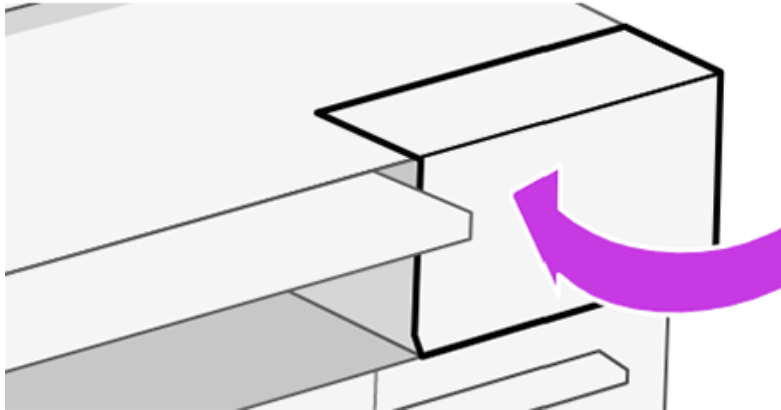

16. Close the main door and follow the instructions on the control panel.

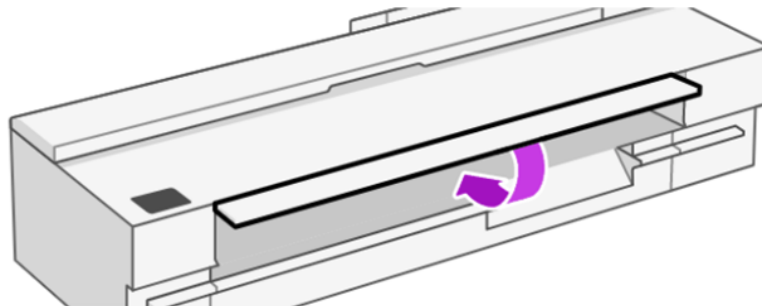

The control panel now recommends a printhead alignment.

The printer prepares the printhead for use.

 **NOTE:** Do not open any covers during this process.

Printzone.
1300 782 636